

EN1092-1/11B Weld Neck PN40 Flange

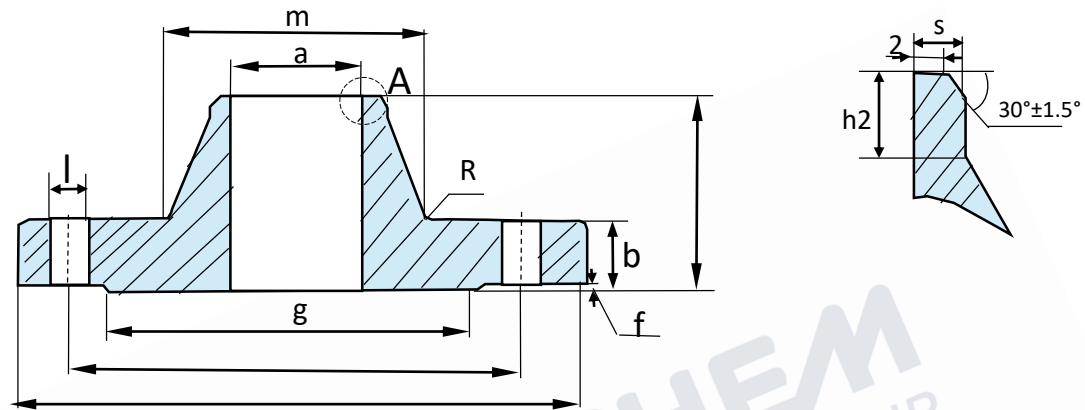

Pipe Nominal size	Flange					Neck				Raised face		Screws			Weight kg
	a	D	b	k	h	m	s	r	h2	g	f	No. of holes	Thread	l	
2	60.32	165	20	125	48	75	2.9	6	8	102	3	4	M16	18	2.85
2.50	73.03	185	22	145	52	90	2.9	6	10	122	3	8	M16	18	3.68
3	88.90	200	24	160	58	105	3.2	8	12	138	3	8	M16	18	4.78
4	114.30	235	24	190	65	134	3.6	8	12	162	3	8	M20	22	6.46
5	141.30	270	26	220	68	162	4	8	12	188	3	8	M24	26	8.86
6	168.28	300	28	250	75	132	4.5	10	12	218	3	8	M24	26	11.7
8	219.08	375	34	320	88	244	6.3	10	16	285	3	12	M27	30	21
10	273.05	450	38	385	105	306	7.1	12	18	345	3	12	M30	33	34.2
12	323.85	515	42	450	115	362	8	12	18	410	4	16	M30	33	47.6
14	355.60	580	46	510	125	408	8.8	12	20	465	4	16	M33	36	69.3
16	406.40	660	50	585	135	462	11	12	20	535	4	16	M36	39	98
18	457.20	685	57	610	135	500	12.5	12	20	560	4	20	M36	39	105
20	508.00	755	57	670	140	562	14.2	12	20	615	4	20	M39	42	130